

# **Process Modeling Using System Dynamics: A Combined Case Study and Tutorial**

**Max Hughes**

## **Preface**

This is a case study that demonstrates the multiple benefits that can be gained from simulating business processes using system dynamics techniques. One always gets an understandable map of the process, usually the first that anyone in the firm has been able to construct. Then there will be the answer to whatever question sparked the effort in the first place followed by a variety of totally unexpected insights, and, finally, the residues of a new way of looking at the world and a new set of operating parameters to be tracked.

Since too few people appreciate the utility of system dynamics in modeling business processes, while others incorrectly believe that it is too esoteric, the construction of the model is discussed in considerable detail.

## **The Problem**

The real sponsor was a venture capital firm that was getting anxious about seeing a return on its investment in a software house that developed and marketed a big HR package. The software house was ambivalent about "I'm from the investors and I'm here to help you", and the initial meeting with the CEO, the CFO and the VP Operations required some serious tap dancing. How can you explain to a CEO that his mental model of how the firm works is probably both wrong and different from those of other executives, and that simulating the key processes would yield valuable, unpredictable insights. But since it was all free to the firm, why fight it? So they listened and became mildly intrigued while the use of system dynamics simulation for another company was presented. They cautiously probed how such a technique might help them.

The executives said they were worried about having sufficient funds for an essential upgrade of their sole product while providing a return to the VC, to whom the CEO said he had a hard time explaining his business. The executives were also concerned about their key technicians burning out. Ultimately, the CEO said he would welcome anything that identified a point of leverage. The CFO, the VP, Operations and the writer became the core modeling team.

## **The Hot Issue**

The writer initially thought that the biggest pressure on the firm was finding the funds to undertake essential product improvement while paying off the backers, and began sketching models that focused on the flow(s) of money, and highlighted the effect of having an updated product. But it soon became apparent that what was really uppermost in the firm's concerns was the fear of burnout of the key technicians assigned to the ongoing operations of the firm, i.e. not those associated with product development and maintenance.

## **Begin Modeling**

System dynamics modeling is based on representing the problem in terms of stocks and the flows in and out of them, and the first step is to identify what flows in the main process, which in this case are customers.

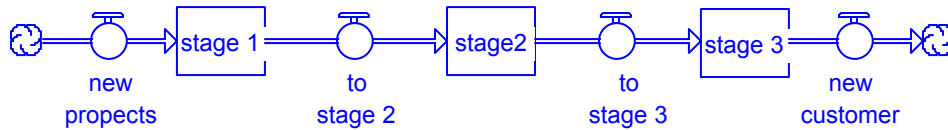

Figure 1.

The firm managed the sales as proceeding through 3 long stages, each lasting at least 6 months, The above depicts a flow of **new prospects** into a stock labeled **Stage 1**. The new prospects in **Stage 1** flow into **Stage 2**, where they stay for however long that stage takes, and then onto **Stage 3** from which they flow out as **new customers**. But of course not every **new prospect** proceeds to the next stage, so each stage has a secondary outflow of **dropouts**:

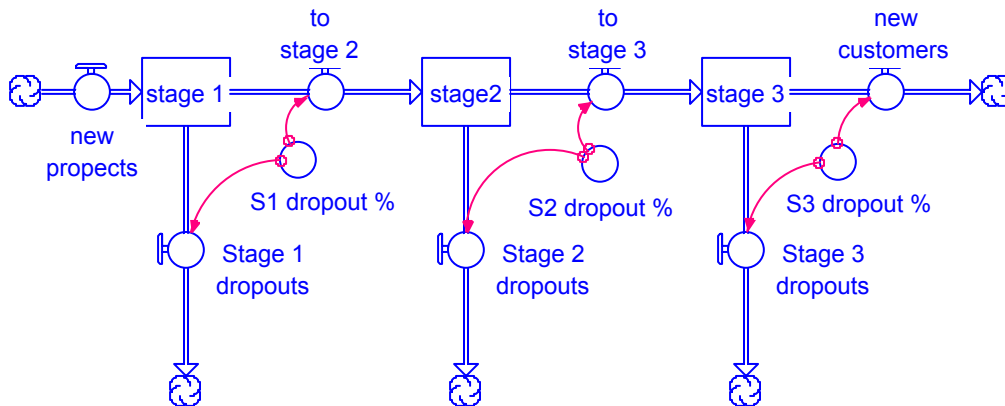

Figure 2.

Controlling the valves on the alternative outflows of each stage are the auxiliary variables **S<sub>n</sub> dropout %**, for which the firm had the data. (to avoid clutter only the connectors germane to the point being discussed are shown, in red, in each diagram).

### Completing the Main Flow

Once a customer signs the requisite contract, he proceeds to an **Installation** stage when the software is installed on the customer's computer(s), the new software melded with other HR processes, the training manuals written, the staff trained etc. etc., on completion of which the customer is added to the installed base.



Figure 3.

In the same way that the firm chose to model selling in the three stages by which it managed the sales effort, installation could have been modeled in multiple sequential and parallel steps had the need arisen. One major activity that was included was the **customization** of the product for each customer, and which began some weeks after the start of **installation**. The equation **begin = delay (new customer, customization delay)** will be entered in the valve **begin**.

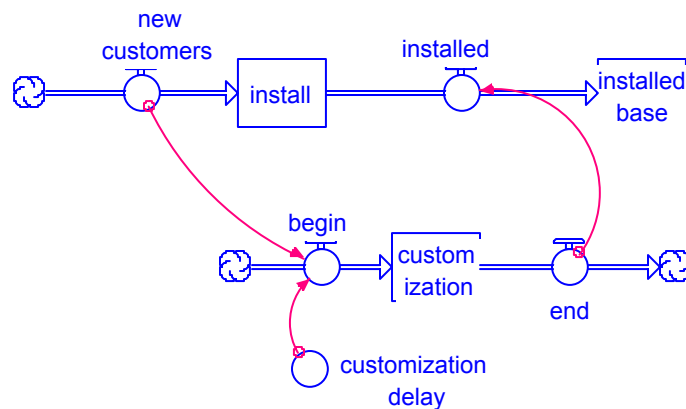

Figure 4.

### Introducing Resource Constraints

Technicians were obviously required for installation and customization, but the VP of Sales was very insistent that the team recognize that no serious selling effort could proceed without a senior technician being available to explain the technical aspects of the product, particularly to answer questions of exactly how the product would interact with a customer's other systems.

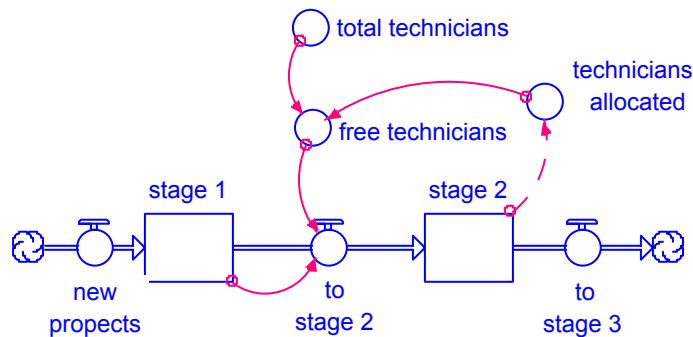

Figure 5.

The extract (above) from the process map shows the way in which customers are prevented from proceeding from stage 1 to stage 2 unless the requisite number of technicians are available. Suppose the Sales VP insisted that a technician had to be available for  $\frac{1}{4}$  of the time a customer was in stage 2, then the valve **to stage 2** would allow one customer to pass for every  $\frac{1}{4}$  technician in **free technicians**, the value of which is the difference between the firm's **total number of technicians** and the number of them already allocated to tasks. This has to be modified so that the number of customers flowing is of course no greater than the number in stage 1, so that the actual equation written in the dialog of the valve is **to stage 2 = maximum of free technicians \* 4 and customers in stage 1**. The dashed information connector from **stage 2** to **allocated technicians** ensures that for every customer in **stage 2**, the number of **allocated technicians** is increased by  $\frac{1}{4}$ , and is correspondingly decreased as each customer completes **stage 2**.

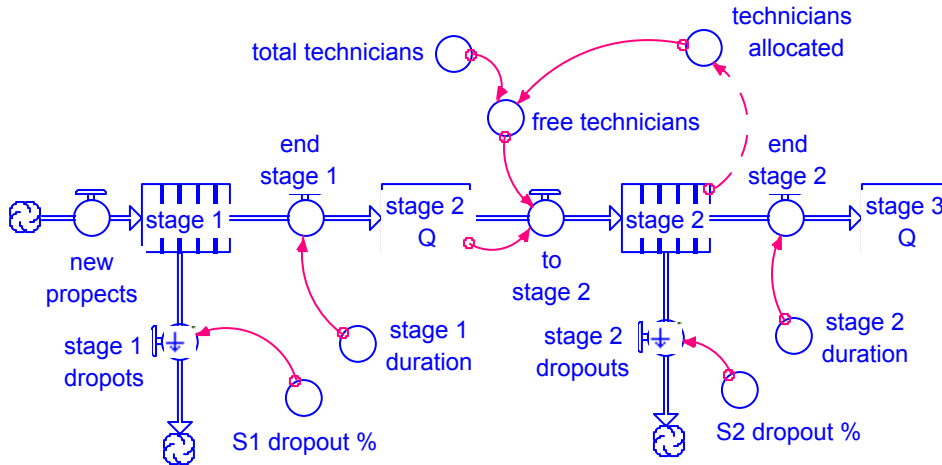

Figure 6.

### Introducing Activity Duration

To deal with the situation where a customer finishes a stage, but there are not resources to begin the next, each stage is followed by a holding queue - **stage 2 Q** for example. At this point we introduce one technique for setting the duration of each activity. The software used here, iThink, has a variant on stocks, called conveyors, which act as you would expect: objects get on at one end and get off the other after **stage n duration**, which maybe fixed vary about some average, or be some other distribution.

Furthermore, **dropouts** can be set to occur only after the stage has been completed or fall by the wayside at any time, including after some minimum time. The complete map will have connectors from each of the three **stages** of selling and from **customization** and **install to technicians allocated**, some of which are shown in the next diagram.

### More Business Rules

The information connector from **install Q** to the flow **to Stage 2** allows the modeling of another business rule, which says if the number of new customers for whom installation has not begun

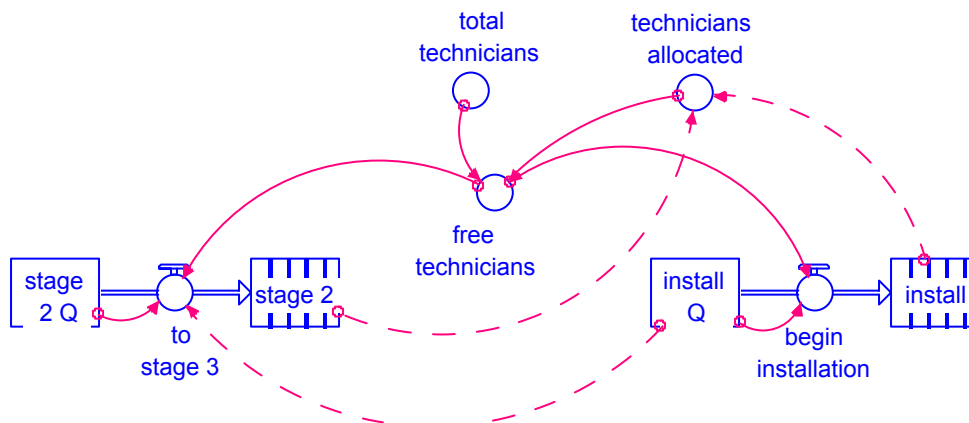

Figure 7.

exceeds some specified number then no effort will made to move potential customers further along the selling process. This will mediated by the connector from **installation Q** to **stage 2**. The model ultimately included a complete set of rules about the order in which demand for

---

technicians at each of the three stages of selling, installation and customization were to be satisfied.

### Not All Technicians are Equal

The Sales VP also instigated the next level of modeling when he pointed out that not just any technician was needed to help sell, only the truly seasoned senior ones. And it was apparent that some installation tasks also required senior technicians, but that some tasks could be well performed by juniors. Thus the technician pool was divided into four levels A's (rookies), B's, C's and D's (experts), and the firm was small enough that the CEO had no difficulty in assigning a grade to each technician. ( a model was made of the progression of technicians through the grades, incorporating how long it took to mature to the next grade, the percentages who would make each transition, and quit rate of each grade etc.). With an appreciation of the qualities possessed by each grade the team was able to state, for example, that installation required so many A's, so many B's, so many C's etc., and that stage 2 of selling needed so many D's.

### Conflicting Mental Models

Up to this point there had been no discussion about what exactly defined the three stages of selling. "Why that's easy", said the Sales VP, "it's all described in the Sales Manual". "It's also written up in one of the Administration Manuals", chimed in the CFO. "I believe I have something on that in a presentation I made", added the President. And they were all different from one another! So here's a firm managing a key process with three key players having different mental models. This is not as unusual as one might imagine, in fact where no formal description of a process exists, it is usually the case that each person has his own, unique impression of it. In the current example it was finally agreed that a customer moved from stage 1 to stage 2 when the customer had established a budget to purchase at least somebody's HR package.

### Discrete versus Continuous Flows

So far the model has been presented as though there were a steady flow of **new prospects**, leading to steady flow of **new customers**, but in reality **new prospects** were identified much more randomly, which can be simulated by using a Poisson distribution - simply done by setting the flow rate of **new prospects** equal to  $\text{Poisson}(\text{avg sales rate})$ .

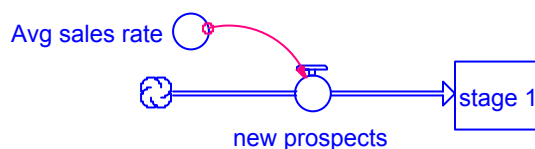
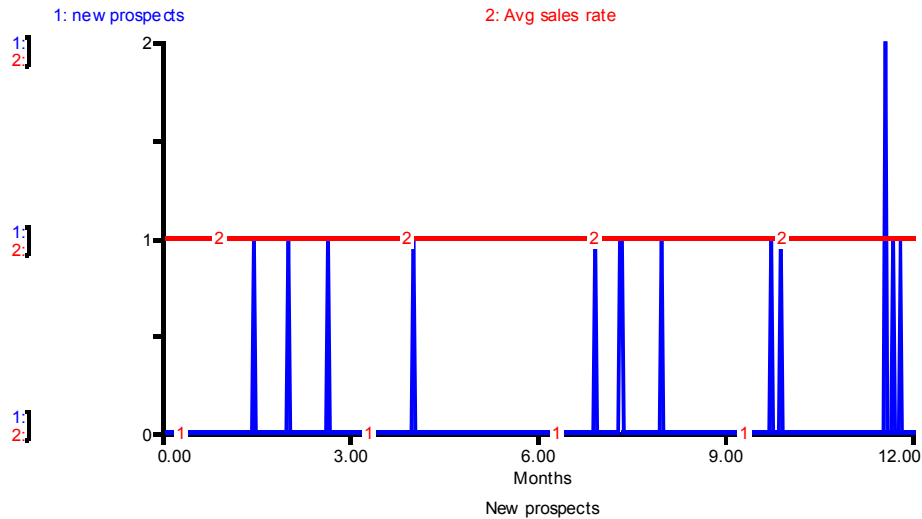

Figure 8.

The writer was somewhat diffident about introducing Poisson concepts to the group, but when the CFO saw graphs like the one below he became very animated, for he recognized that they illustrated the source of the problems he had convincing others of the inadvisability of projecting financial results based on data for latest quarter. Quarter 1 is fine, with the expected 3 new prospects, but there was only 1 in the next quarter.



Graph 1.

Ah! we are back on track quarter, only to be swamped with 6 in the last, including two in the same week.

### Disappointment

The early simulations were disappointing in that the firm appeared to have plenty of technicians and there was no build up customers in any of the queues. The first modification was to recognize that the demands placed by customers varied widely. Some bought the product essentially off the shelf, requiring minimal installation effort and no customization; but others required extensive installation and customization, making the selling and contract negotiation that much more complex. The price to these two sets of customers varied ten-fold. So, the single process was replaced by three parallel streams. And still no bottlenecks appeared in the simulations.

### Success

The model finally replicated reality more closely when it was reluctantly admitted that not all D technicians were equal, nor were the C's. Some very good senior technicians were really not good communicators and should not be called on to help with selling. By now it was apparent that the firm had an adequate supply of A's and B's, so that the model could be limited to the supply and allocation of C's and D's. It turned out that the minimum number of types was 5, designated by their level and their competencies. A Dsci technician was a D level who could sell, install and customize; a Ci was a C level who should only effectively be assigned to installation

### Some Output

Graph 2 shows the effect of the number of the most versatile technicians on the growth of the installed base, and the importance of the D level technicians. By plotting the number of each kind of technician that was free, meaning unassigned to a task, it is clear that it was C level technicians that were in shortest supply, in particular those that were good at installation (graph 3) This is confirmed in graph 4, where the availability of C level technicians is least for installation. The spikes in the graphs correspond to technicians finishing one task and not yet allocated to the next, and could indeed correspond to them traveling to the next installation.

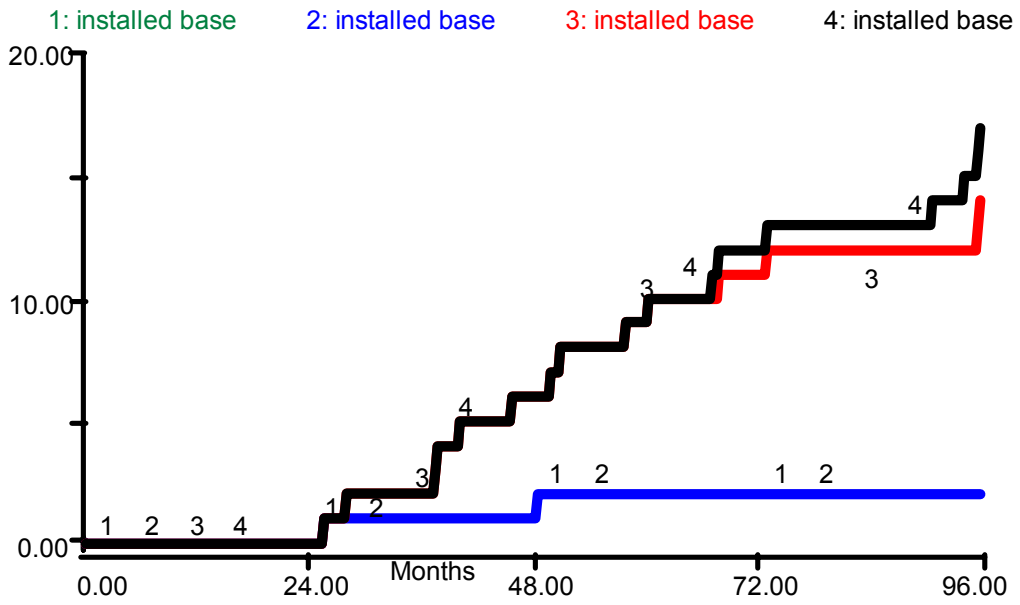

Graph 2.

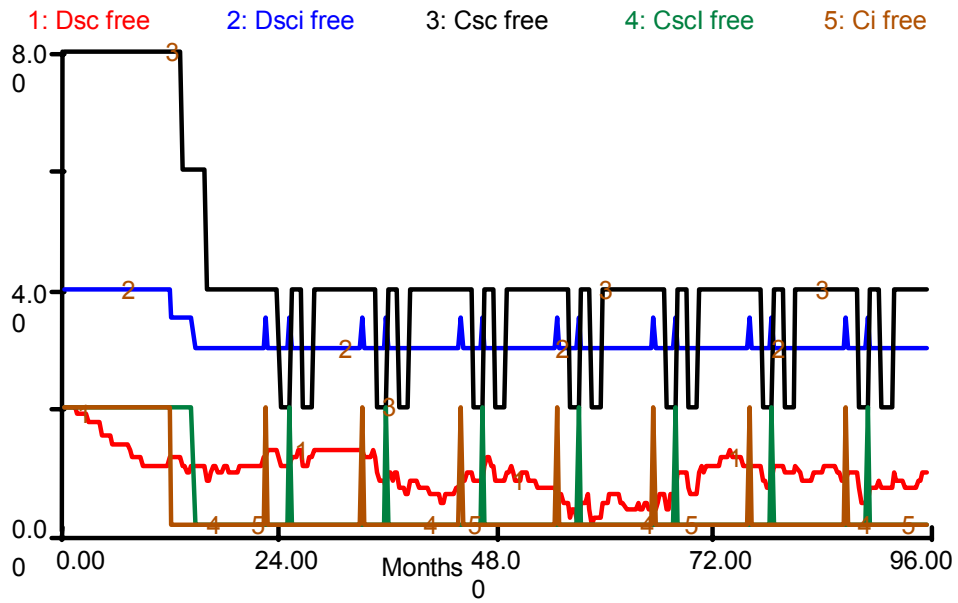

Graph 3.

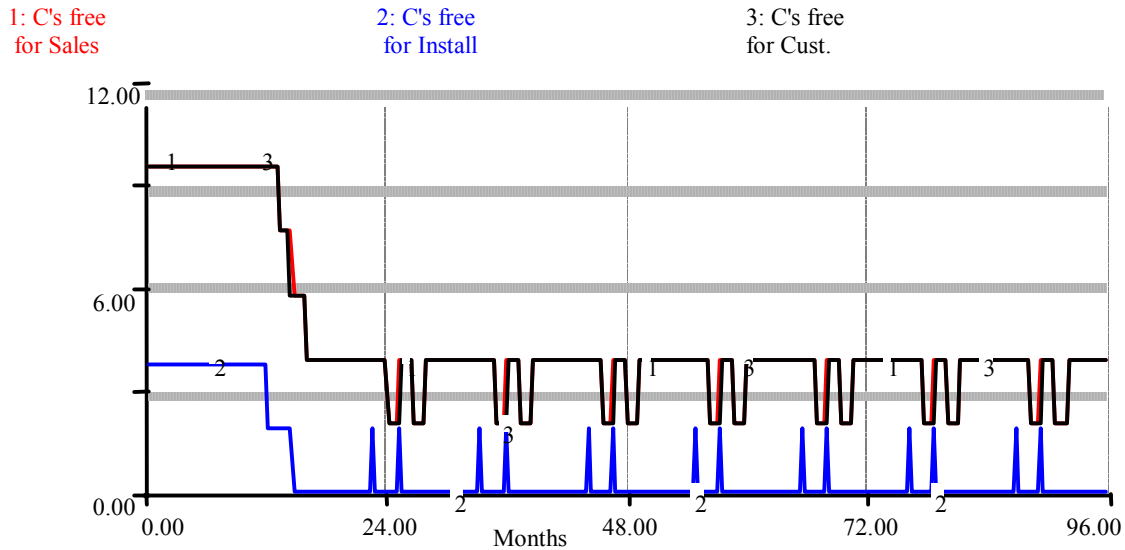

Graph 4.

### Final Details of the Model

The introduction of five classes of technicians meant that another business rule was required. Supposing that for a task requiring a C technicians and there are both Ci and Ccsi technicians available, which to assign? Assigning the most specialized first was adopted, in this case Ci. Thus the model had two important sets of business rules, one governing the priority of tasks, and the other the order of assigning technicians. In all fairness, this is fairly straight-forward but with more than a few tasks and alternative resources creating this part of the model can be very tedious.

### The Answer

The Answer to the initial challenge of identifying a leverage point was that the firm needed to increase the number of C level technicians that were good at installation, and indeed the next hires the firm made and internal training were targeted on just that.

### What Else did the Client Get?

Firstly, a map of the relevant processes, and for many firms this is usually a breakthrough following failed attempts using the symbols of the logic flow of a computer program. The map not only showed the order and interdependence of activities, but included their capacity, their duration and the policies that governed these. Furthermore the effect of changing any or all of the variables could be seen.

The process map also becomes the mental model that will dominate the decisions that the managers make from now on. Each manager will also be operating from the same, communicated mental model.

Every model building effort yields an. aha! moment .in this case the discovery of the divergent mental models of the stages in the selling process. We will never know the effect of this particular mental model mismatch. We do not know the effect of each executive interpreting the monthly statistics differently. We do not know if it induced different perceptions of the state of the

---

business and if this affected routine operating decisions. But it is clearly essential that the senior members of a firm operate from the same set of assumptions about the how the firm works.

The modeling effort will permanently affect the way the participants address problems. People exposed to system dynamics are for ever changed and the firm will be ready to embrace system thinking - the fifth discipline of Peter Senge's learning organizations. In the current case it was the CFO who really appreciated having "a new way of looking at things."

Finally, the firm will have come to appreciate that it would benefit from tracking some new operating parameters. For example this firm has already got a new classification scheme for its technicians. But there will be a generally increased awareness on the importance of tracking the dates on which everything occurs so that the duration of activities and rates of progress can be calculated.

-----  
Max Hughes, a consultant and professor of Information Science and Technology at Drexel University. Dr. Hughes can be reached at [max.hughes@cis.drexel.edu](mailto:max.hughes@cis.drexel.edu)